

# CD150M JCB FT4 Dri-Prime® Pump

The Godwin CD150M Dri-Prime pump with JCB TCAE-55 Final Tier 4 engine offers flow rates to 2290 USGPM and has the capability of handling solids up to 3" in diameter.

The Godwin CD150M Dri-Prime pump is able to automatically prime to 28' of suction lift from dry. Automatic or manual starting/stopping available through PrimeGuard 2 control panel. Field Smart Technology (FST) wireless remote access optional.

Indefinite dry-running is no problem due to the unique Godwin liquid bath mechanical seal design. Solids handling, dry-running, and portability make the Godwin CD150M Dri-Prime pump the perfect choice for dewatering and bypass applications.

## Features and Benefits

- Simple maintenance normally limited to checking fluid levels and filters.
- Dri-Prime (continuously operated Venturi air ejector priming device) requiring no periodic adjustment. Optional compressor clutch available.
- Extensive application flexibility handling sewage, slurries, and liquids with solids up to 3.0" in diameter.
- Dry-running high pressure liquid bath mechanical seal with high abrasion resistant solid silicon carbide faces.
- Close-coupled centrifugal pump with Dri-Prime system coupled to a diesel engine or electric motor.
- All cast iron construction (stainless steel construction option available) with cast steel impeller.
- Also available in a critically silenced unit which reduces noise levels to less than 70 dBA at 30'.

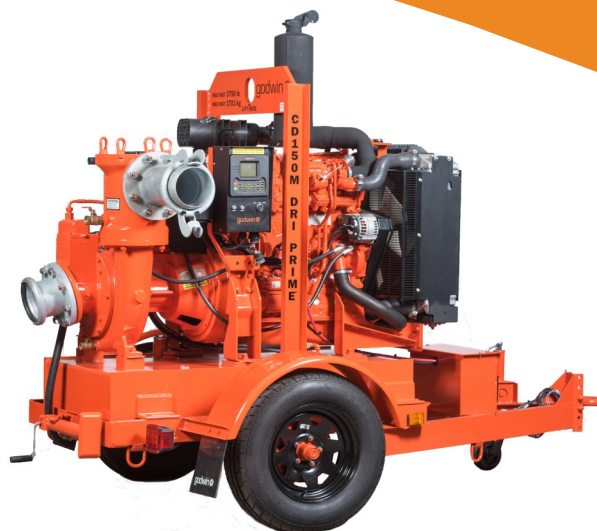

## Specifications

Suction connection	6" 150# ANSI B16.5
Delivery connection	6" 150# ANSI B16.5
Max capacity	2290 USGPM †
Max solids handling	3.0"
Max impeller diameter	11.0"
Max operating temp	176°F*
Max pressure	70 psi
Max suction pressure	58 psi
Max casing pressure	105 psi
Max operating speed	2200 rpm

\* Please contact our office for applications in excess of 176°F.

† Larger diameter pipes may be required for maximum flows.

## JCB Final Tier 4 Engine

- Fully electronic engine
- Emissions reduced through incylinder technology - no DPF
- Compact design

## Performance Curve

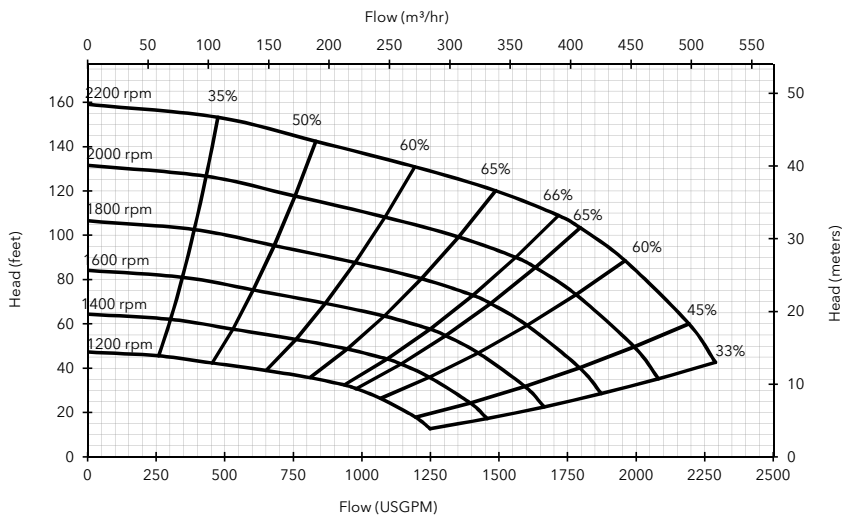

## Materials

Pump casing & suction cover	Cast iron BS EN 1561 - 1997
Wearplates	Cast iron BS EN 1561 - 1997
Pump Shaft	Carbon steel BS 970 - 1991 817M40T
Impeller	Cast Steel BS3100 A5 Hardness to 200 HB Brinell
Non-return valve body	Cast iron BS EN 1561 - 1997
Mechanical seal	Silicon carbide face; Viton elastomers; Stainless steel body

## Engine option 1

JCB TCAE-55 (FT4), 74 HP @ 2200 rpm

Impeller diameter 11.0"

Pump speed 2200 rpm

### Suction Lift Table

Total Suction Head (feet)	Total Delivery Head (feet)				
	30	46	62	81	121
	Output (USGPM)				
10	2179	2131	2083	1889	1356
15	2058	1937	1816	1574	1162
20	1453	1453	1453	1332	848
25	1259	1211	1114	969	484

Fuel capacity: 60 US Gal

Max Fuel consumption @ 2200 rpm: 3.9 US Gal/hr

Max Fuel consumption @ 1800 rpm: 3.7 US Gal/hr

Weight (Dry): 3,200 lbs

Weight (Wet): 3,630 lbs

Dim.: (L) 119" x (W) 66" x (H) 77"

Performance data provided in tables is based on water tests at sea level and 20°C ambient. All information is approximate and for general guidance only. Please contact the factory or office for further details.

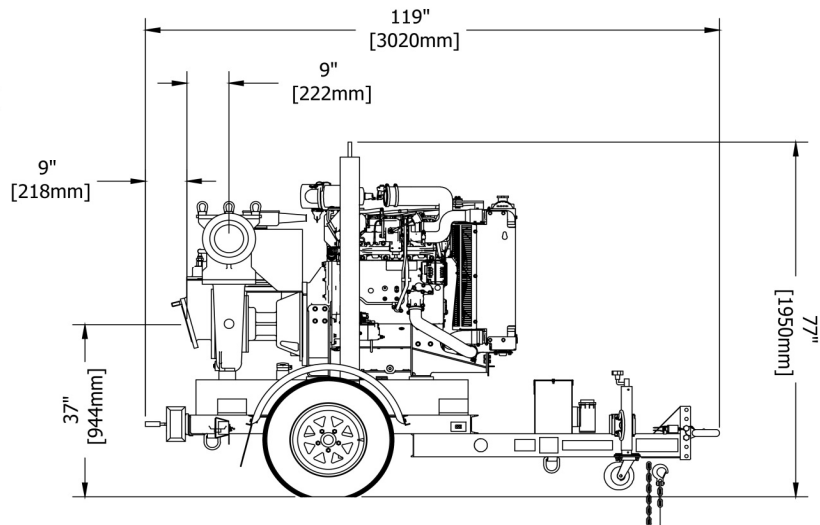
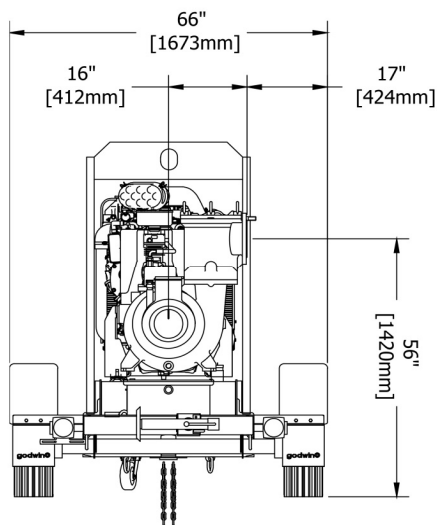

84 Floodgate Road  
Bridgeport, NJ 08014 USA  
(856) 467-3636 . Fax (856) 467-4841

Reference number : 95-1024-3000  
Date of issue : October 24, 2014  
Issue : 1

[www.godwinpumps.com](http://www.godwinpumps.com)