

DPC300 Dri-Prime® Pumps

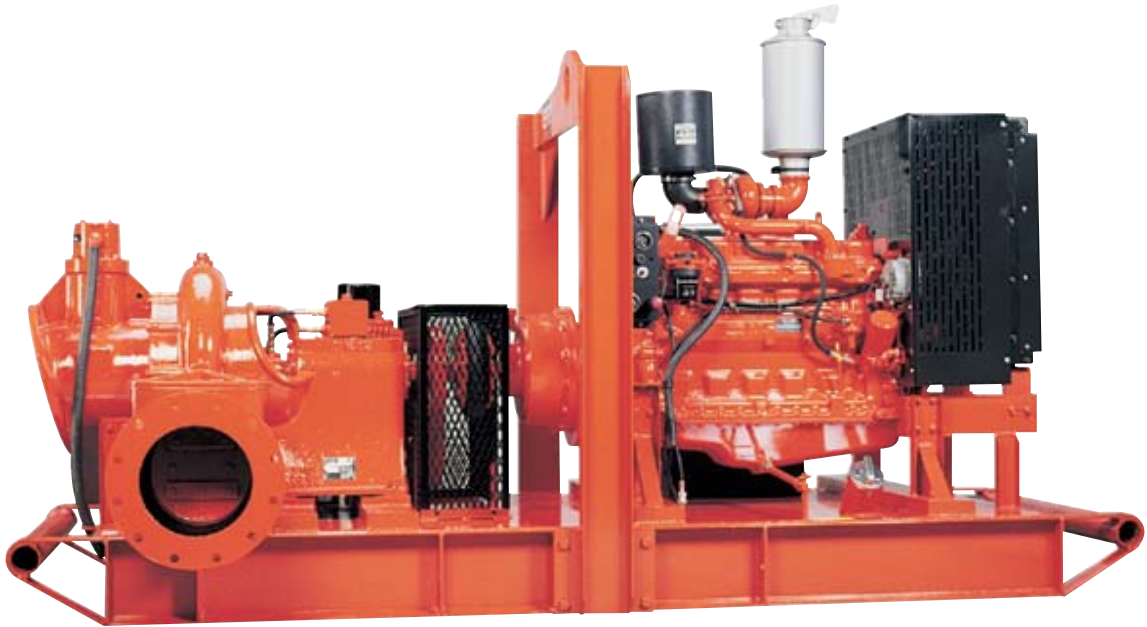

The Godwin DPC300 automatic Dri-Prime 12" (300mm) centrifugal pump has gained recognition as the industry leader in high volume bypass pumping over the last fifteen years. With flows to 5,000 gallons per minute (315.5 l/sec.) and solids handling to 3-1/2" (89mm) in diameter, the DPC300 moves large volumes of water while providing the ease of automatic priming to 28 feet (8.5M). The convenience of a low profile discharge flange makes pipe connections easy and efficient. When the job calls for high volume, the Godwin DPC300 is the benchmark by which all others are judged.

Features

- Direct drive automatic priming 12" (300mm) high volume centrifugal pump with vacuum priming compressor mounted to a diesel engine. Available in electric drive or as bare shaft pumpend.
- All cast iron construction with 4 vane cast iron impeller.
- Extensive application flexibility — will handle raw sewage, sludges and liquids with solids up to 3-1/2" (89mm) in diameter.
- Continuously operated "Godwin" air ejector priming device requiring no form of periodic adjustment or control.
- Dry running, oil lubricated, mechanical seal with abrasion resistant solid silicon carbide interfaces.
- Solids handling swing check Non Return valve at pump discharge.
- Skid base incorporating integral overnight running fuel tank.
- Simple maintenance — normally limited to checking engine oil, compressor oil, and seal lubrication.
- Standard engine — John Deere 6068T. Available with a variety of engines including Cummins, Caterpillar and Deutz.
- Low profile side discharge for easy pipe connection.
- Balanced unit with centralized lifting bracket for easy handling.
- A variety of silenced units are available.

DPC300 Performance Curve

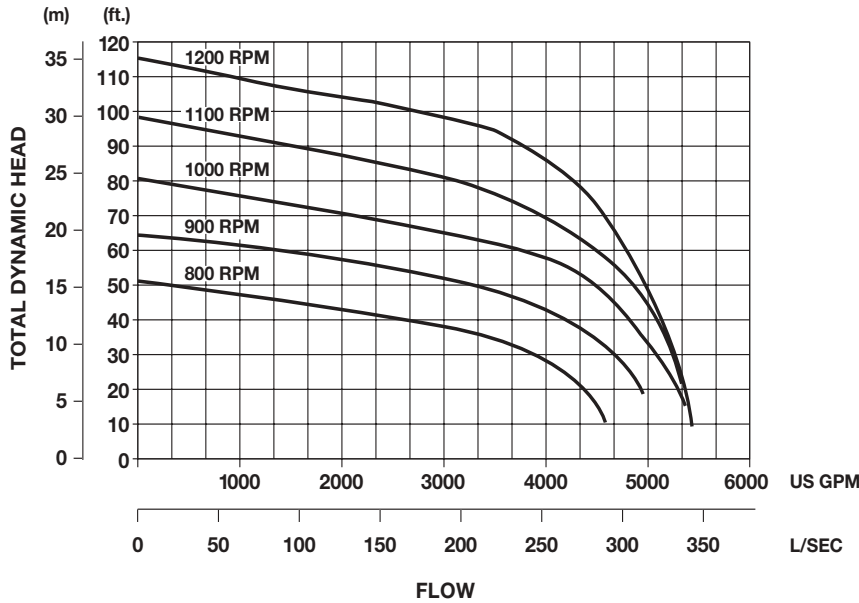

Performance Table

Diesel Set: John Deere 6068T, 151 hp (113kw) @ 2400 rpm, Skid Base
Impeller Diameter: 17 inches (430 mm)

Head — Feet	Total Delivery Head — Feet				
	10	20	30	40	50
	Output — GPM				
10	5810	5620	5000	4490	3115
15	5500	5140	4710	4250	2900
20	4600	4500	4230	3130	1415
25	3875	3730	3250	2105	960

Performance data listed in table and curves are based on water tests at sea level and 68° F (20° C). Larger diameter pipes may be required for maximum flows.

Dimensions

DPC300 — John Deere 6068T, Skid Base
 Weight: 7,265 lbs. (3,295 kg.)

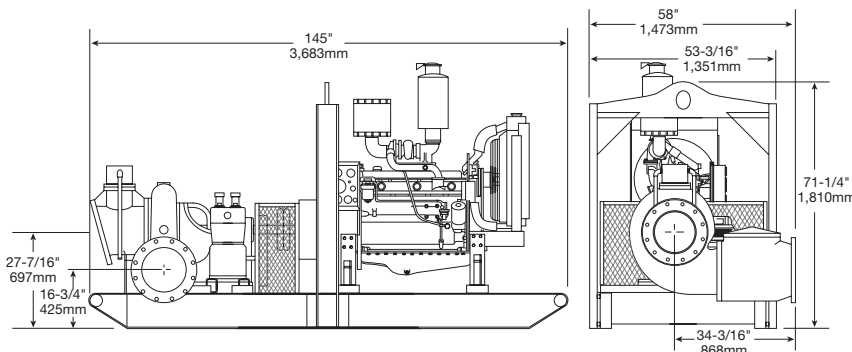

Specifications

- Maximum Operating Speed:**
Engine: 2450 rpm/Pump: 1200 rpm
- Maximum Operating Temperature:**
+212° F (100° C)
- Maximum Working Pressure:**
52.0 psi (3.6 BAR)
- Maximum Suction Pressure:**
30 psi (2.1 BAR)
- Maximum Casing Pressure:**
75 psi (5.2 BAR)
- Fuel Tank Capacity:**
105 and 150 gal. sizes available
(397 and 548 liters)
- Fuel Consumption:**
7.8 gph (29.52 lph) @ 2400 rpm
(full load & max. speed)
- Pipe Connections:**
12 inch (300mm) ASA 150#
- Solids Handling:**
3-1/2" (89mm) diameter

Materials

- Pump Casing, Suction Cover, Separation Tank and Wearplates:**
Close Grained Cast Iron
- Pump Shaft:**
1-1/2% Nickel/Chromium Steel
- Non Return Valve Body Ejector Housing:**
Close Grained Cast Iron
- Non Return Valve Flapper:**
High Nitrile Rubber
- Mechanical Seal Faces:**
Solid Silicon Carbide



One Floodgate Road, Bridgeport, NJ 08014, USA
 (856) 467-3636 • Fax: (856) 467-4841

Quenington, Cirencester, Glos., GL7 5BX, UK
 +44 (0)1285 750271 • Fax: +44 (0)1285 750352

E-mail: sales@godwinpumps.com
 www.godwinpumps.com

BRANCH LOCATIONS:
 Connecticut • Pennsylvania • New York • Ohio
 Illinois • Maryland • Virginia • West Virginia
 Georgia • South Carolina • North Carolina
 Florida • Texas • Montana • California • Washington

Dri-Prime® and the color orange for pumps are registered trademarks of Godwin Pumps of America, Inc.
 Specifications and illustrations are subject to revision without notice.
 © Copyright 2003-2005 Godwin Pumps of America, Inc.
 All rights reserved.